

PRODUCT SPECIFICATION

DESCRIPTION----80W Phillip LED Flood Light



LM79
LM80



● Features



- | | | | |
|--|--|---|--|
| ① | ② | ③ | ④ |
| Energy-saving | Eco-friendly | Easy to use | Long life-span |
| Saving more than 80% power Energy than traditional lamps | No UV/IR, Safe solid Light source, No Mecury & lead. | Instant Start , No Flicker ,Free main-tance | More than 80,000 hours long lifespan. Low light failure. |

● Technical Parameter

Model	GT-FL80W
Power	80W
Voltage	AC90-277V OR 347V
Working Frequency	50-60HZ
Power Efficiency	>95%
Luminous Flux	7,200LM
Power Factor	>0.90
Color Temperature	WW: 2700 - 3300K NW:4000 - 4500K CW: 5000 - 5500K
CRI	Ra \geq 75
Beam Angle	130°
Working Temperature	-30 to +60 °C
IP Rate	IP65
Life-span	50,000hrs life, 5 Years Warranty

● Lux Parameter

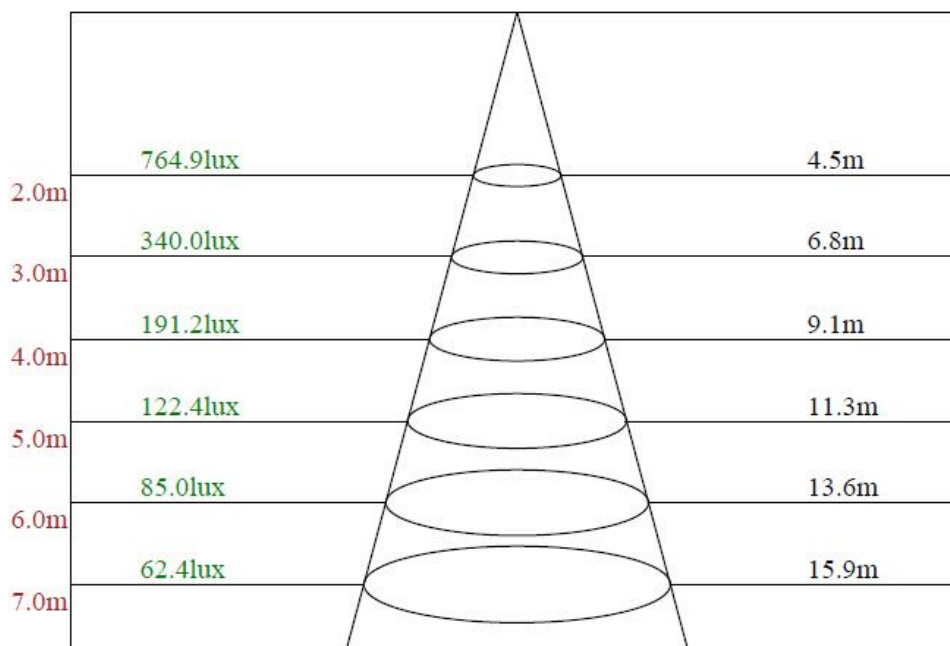

Beam angle of C90plane97.16

● Light Distribution Curve [Unit:cd]

Light Distribution Curve [Unit: cd]

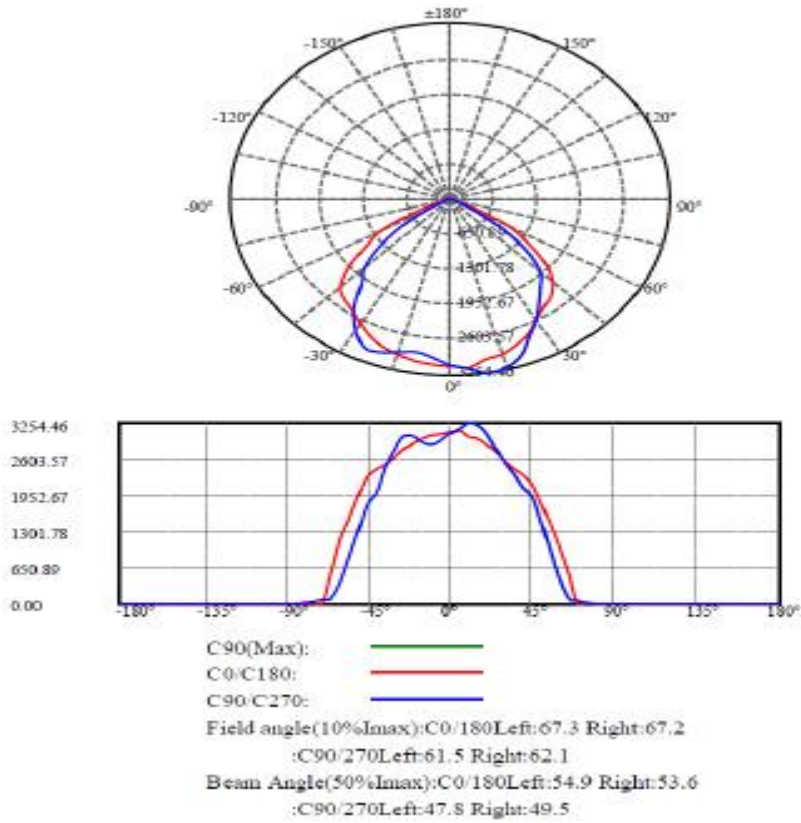

● Dimension

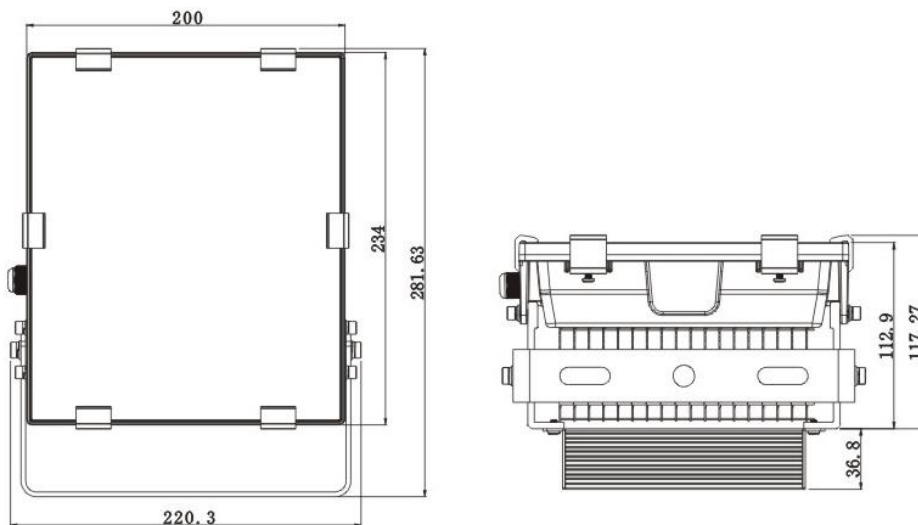

● Product Details

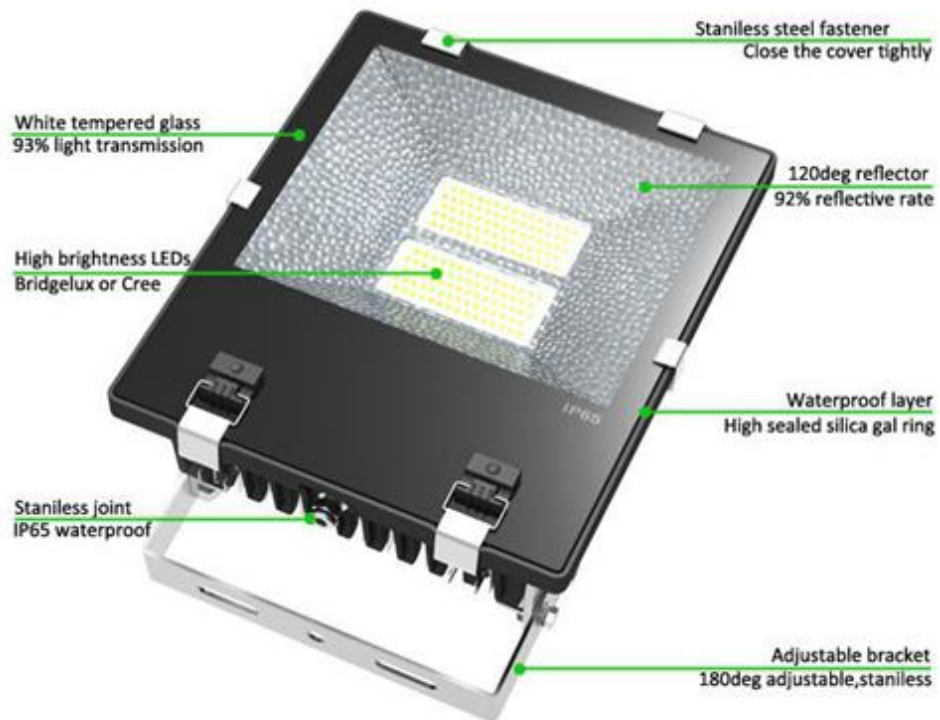

● Product Package

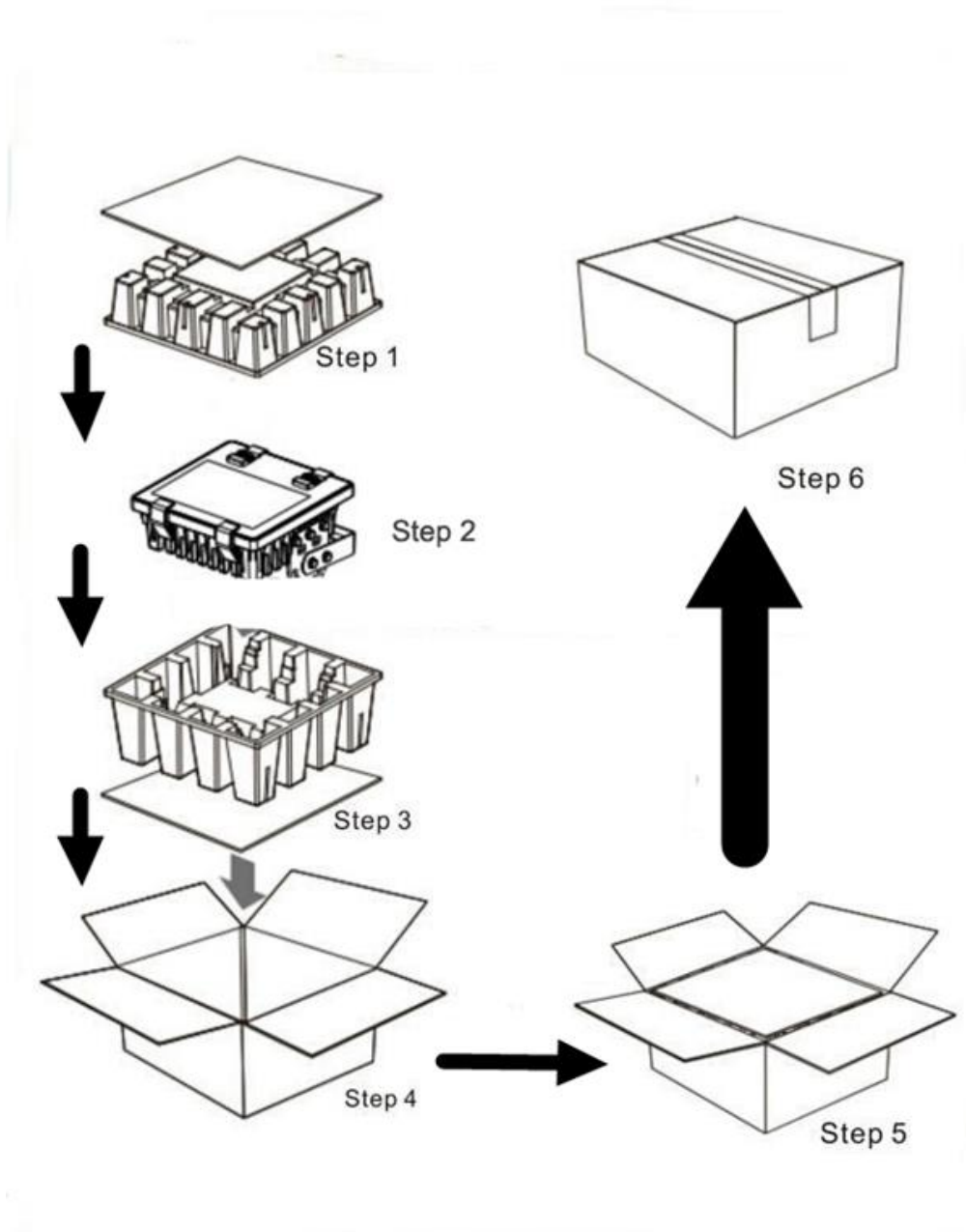

● Installation

- 1、 Before installation, please check the installation guide as Diagram1, Diagram 2 and Diagram 3 shows.
- 2、 Please fix the stands of the fixtures on the mounting holes and lock the stands by screws.
- 3、 Ensure the luminous direction is down. just like Diagram 4 shows.
- 4、 Connect (L: Black N: White GND: Green), According to the American connection standard.
- 5、 IP grade: IP65
- 6、 Switch on power
- 7、 Please see attached connection instructions

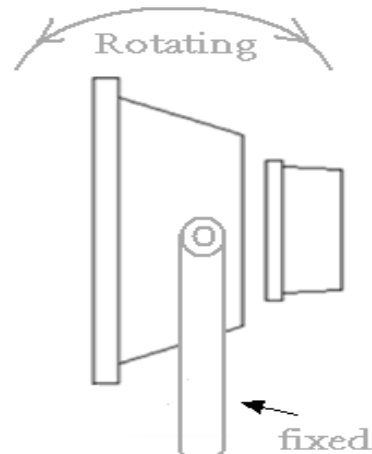
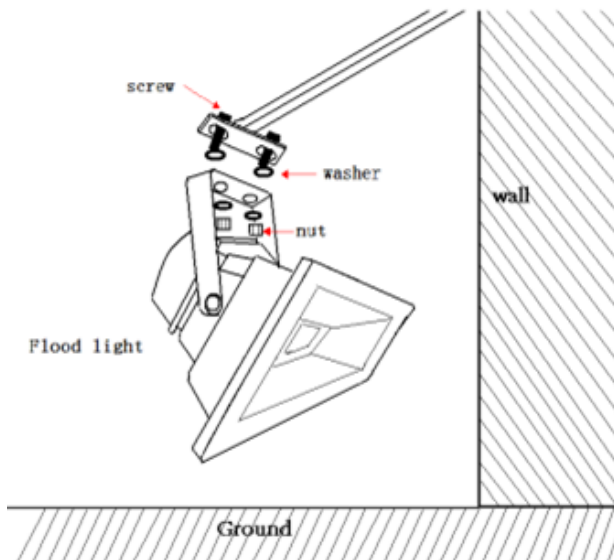
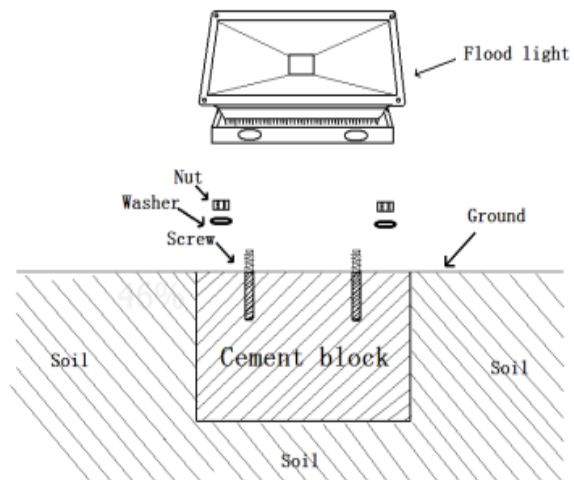
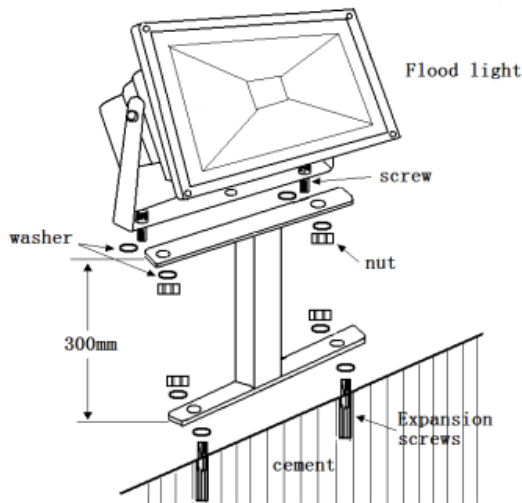

● Products Application Cases



The date mentioned in this file is for reference only, and the specific date should be subject to the specified products.

